

Multi-purpose rotor loader wagon
JUMBO

 **PÖTTINGER**

Two steps ahead



Two steps ahead



With the new JUMBO you are always two steps ahead.

The JUMBO is a high-performance loader wagon that delivers maximum output, high efficiency, excellent reliability and the best operator convenience. It guarantees enjoyable work and high yields. The new range brings you safely through the harvesting season and is also ideal for transporting goods of all kinds at other times too.

Table of contents

The best forage	4-5
Efficiency and high output	6-15
Highest forage quality	16-33
Reliability	34-43
Cost effectiveness	44-47
Convenience and maintenance	48-53
Digital agricultural technology	54-57
Intelligent operation and ISOBUS terminals	54-55
Manufacturer-independent data transfer – agrirouter	56-57
Accessories	58-59
Technical data	60-61

All information on technical data, dimensions, weights, output, etc. and the images shown, are approximate and are not binding.

The machines shown do not feature country-specific equipment and may include equipment that is not supplied as standard, or is not available in all regions. Your PÖTTINGER dealership would be pleased to provide you with more information.

The best forage



The basis for your success

The best forage always pays – for farmers as well as contractors.

Focusing on the highest quality forage also helps contractors and forage dealers maintain excellent relations with existing customers and win new ones.

Achieving the best forage begins long before harvesting. A healthy, high-energy and well-balanced crop is essential. The cutting time is crucial for obtaining full energy levels from it.

Once the grass has been mown it begins to respire and lose energy. The longer it is left unattended, the less energy the forage contains. The aim, therefore, is short wilting times and optimum dry matter content in order to achieve the best quality forage.

If the forage is too dry, ensiling will not be ideal, and if it is too wet a lot of energy will be lost through fermentation.

By maintaining sufficient stubble height and using PÖTTINGER agricultural technology to avoid contamination, you will harvest forage of the highest possible quality.

For your customer

As a contractor your task is to harvest the best forage on behalf of your customer in a brief period of time.

If you want the customer to remain with you in future you must ensure his long-term satisfaction.

The success of a farmer's business depends on the quality of the forage you collect for him. If the farmer cannot fully exploit the potential yield of his herd he is likely to withdraw his custom and entrust the work to another contractor.

That gives you sufficient reason to do everything possible from the outset to keep the customer satisfied.

PÖTTINGER agricultural technology provides the ideal basis for this because it ensures optimum ground tracking and consequently minimal dirt ingress.

It is designed for maximum crop protection and highest output. This is doubly important because the best forage has only a short wilting period and you are already due at your next customer.



For your livestock

As a farmer, you know: High yield livestock need a high quality basic ration.

Ruminants are fussy about their forage. The quality of their basic ration is made up of energy content, digestibility, odour, taste and determines whether they eat large amounts of it.

What they like most is basic ration that is clean and tasty. The amount of concentrates used can be reduced. This cuts forage costs while at the same time improving animal health.

Healthy livestock reward you with higher fertility, a longer useful life and, crucially, higher milk and meat yields.

The bottom line is that you benefit from clean, high quality forage with more profit from your farm business.

Don't feed your animals crude ash!

“There are many reasons why high crude ash content prevents cost effective milk production. Best basic ration is required if cows are to remain healthy, fertile and produce a lot of milk. The basic ration should contain as little earth and sand as possible. These contaminants, shown as “crude ash” in feed composition analysis, cause undesirable side effects.

The function of the reticulum-rumen system is reduced. Organisms that affect the ensiling process, such as clostridium, can be brought in. The yield ability, health and fertility of dairy cows suffers as a result.”

Dr. Michael Neumayer
 Veterinarian
 Neukirchen am Großvenediger | Austria

Efficiency and high output



Effective and efficient

The new JUMBO range unites the key features of forage harvesting and transport in a single unit. Crop collection of unrivalled cleanliness, the outstanding reliability of a loader wagon, the flexibility and capacity of a handling trolley, precise chopping quality and the high throughput of a forage harvester. The combination of these characteristics means the JUMBO is unquestionably two steps ahead.

The high demands made on modern high-performance loader wagons in the field have been incorporated into the third JUMBO generation. As a result the JUMBO represents a new performance class.

It is the first loader wagon to work with tractors outputting up to 500 hp, making harvesting a great deal more efficient with a multitude of technical innovations.

Power without compromise

The concept of the new JUMBO was based around the two requirements throughput and mass flow. The impressive new drive train enables significantly improved performance compared to previous models. The innovative drive system with a belt drive and angular/planetary gears in the rotor delivers maximum power coupled with extremely quiet and smooth operation.

Everything under control

Controlled power transmission

Thanks to their soft start characteristics, the rotor and beater driveline can be switched on and off even under load. The damping effect of the Powerband protects the components and ensures a long service life. The torque measurement system informs you of the current torque of the loading rotor.



Controlled pick-up

The controlled floating pick-up has a pick-up width of 2,300 mm as standard.

This ensures rapid and clean crop collection even from irregular or particularly wide swaths.

The pick-up's hydraulically adjustable drive system adjusts speed automatically to the travelling speed.

That is how the JUMBO guarantees a supremely comfortable ride as well as clean and tidy loss-free collection of crop in a single pass.

Enormous loading and unloading power

"We have experienced all the developments of the JUMBO since 2002, from the JUMBO 7200 to the JUMBO 10010 L COMBILINE. They worked very well, but the new JUMBO is something different, it is not comparable, it is a revolution.

"We particularly appreciate the simplicity and consistent performance of the automatic loading system with the intelligent front panel. Unloading is also quite different to the previous model; the new JUMBO is much faster and no forage is ever left behind.

Efficiency and high output



- 1 Belt drive with angular/planetary gears
- 2 Loading system
- 3 Scraper floor
- 4 Moveable front panel
- 5 Beaters



Performance at a new level

The JUMBO has been designed for maximum performance and the greatest efficiency. All the core components have been completely redesigned and subjected to thorough trials on tractors outputting up to 500 hp.

Controlled floating pick-up

The hydraulically controlled floating pick-up with a pick-up width of 2,300 mm according to DIN ensures maximum intake at every loading speed. Pick-up speed adapts as needed between 75 and 125 rpm.

Belt drive with angular/planetary gears

Modern and innovative drive concept for tractors outputting up to 500 hp. The loading torque can be adjusted as required.

Loading system

Maximum throughput thanks to the extended transfer throat and the large rotor with a diameter of 850 mm.

Scraper floor

2-speed motors and a patented boost function deliver best possible unloading performance.

Moveable front panel

The front panel optimises the loading chamber and features an optional intelligent loading and unloading strategy for large loads.

Beaters

The beater driveline with 210 kW of power and the new soft-start drive train protect the driveline components. The new beater rotors with V-twist ensure optimum beating and rapid unloading even with high compaction.

Efficiency and high output



Power transfer reinvented

The innovative, unique drive concept has been designed for tractors outputting from 200 to 500 hp. This means that the JUMBO can be operated with a wide range of tractors.

The driveline has a double wide-angle PTO shaft without a clutch and is powered by a Powerband. Optimum power transmission to the rotor is ensured by angular/planetary gears in the rotor drive.

The Powerband delivers maximum power transfer in all operating conditions. It ensures smooth running and a damping effect in changing operating conditions. This protects the mechanics and reduces maintenance and wear costs to a minimum.

Special overload protection system

A PTO shaft with an overload protection system is subjected to extreme wear-intensive stress when used in high-performance harvesting equipment.

The angling of the PTO shaft during operation produces torsional vibrations which prematurely trigger the overload protection system and negatively impact throughput.

That is why PÖTTINGER decided to decouple the overload protection from the PTO shaft.

Thanks to the newly developed drive concept the JUMBO can be continually operated at up to 3,000 Nm.

The result is optimum protection of all drive components against unnecessary stress and wear-intensive blockages.

Irregular swaths can be picked up with no reduction in speed and no losses, even when cornering. This increases loading efficiency enormously.



Overload safety system

A dynamometer bolt on the belt drive measures the current loading torque.

Detection of an incipient overload significantly reduces blockages.

The drive train is protected by a cam-type clutch immediately in front of the angular/planetary gears.



Powerband

The 6-groove high-performance belt has been designed for extra long life and guarantees reliable power transmission.

It can cope with the toughest demands and also ensures smooth running in all operating conditions. Operating noise is reduced to a minimum.

The belt's damping effect in changing swath conditions benefits loading performance.

The Powerband is maintenance-free.

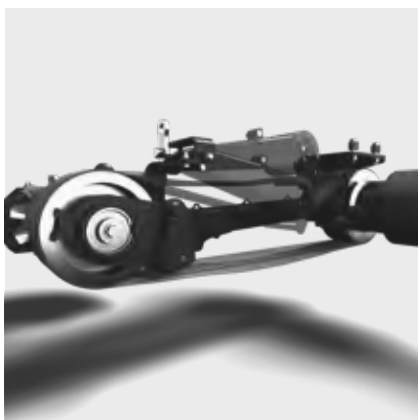

Soft start

Thanks to its soft start, the drive belt enables operation of the rotor and beater rotors even under full load. There is consequently no need to advance the scraper floor when unloading with beater rotors. The scraper floor chains and drivelines are protected, which significantly increases both reliability and the service life of all components.

The drive belt on the JUMBO makes a conventional clutch system unnecessary.

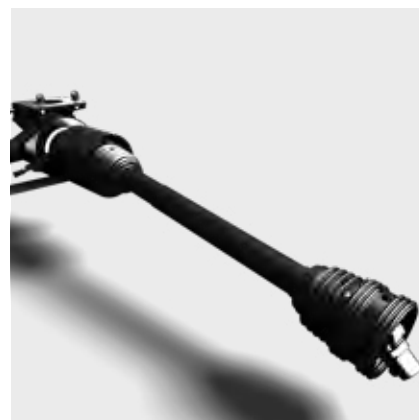

PTO shaft without overload clutch

The innovative design of the drive belt means that no overload clutch is needed on the PTO shaft.

Conventional systems lose as much as 20% of torque owing to angling and the resultant vibrations, especially when cornering.

The JUMBO is therefore able to draw on the full torque of 3,000 Nm, whatever the operating status.

Efficiency and high output

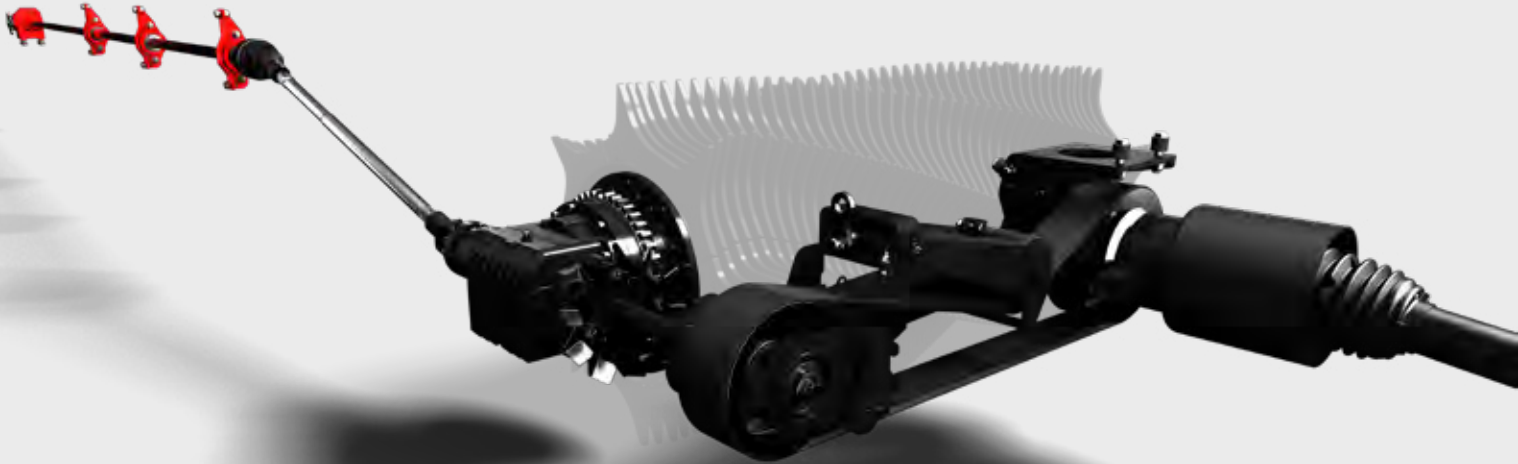

It simply moves more

The heart of the JUMBO series is robust, powerful and designed for almost unlimited tractor power. The rotor and its innovative driveline provide high throughput, perfect chopping quality and, if required, the highest possible compaction.

Thanks to the wide, edged areas at the 12 mm tine tips on the 8-row rotor, it takes over the crop actively and reliably from the pick-up, even if the crop is wet and short.

The rotor tines are arranged in a helix formation, with a diameter of 850 mm to guide the forage smoothly through the 34 mm short-chop knife bank.

The rotor is mounted directly on the chopping system frame in order to protect the rotor drive as much as possible even under heavy load.

A tine form that has been optimised still further, combined with the largest possible scraper surface in the loading chamber, makes compaction of over 400 kg/m³ possible if required.

Driveline

The rotor is powered by angular/planetary gears which lower the high PTO speed to the ideal rotor speed.

On the JUMBO range with beater driveline, the forward-mounted angular gearbox also features a through shaft and an integrated switch.

When the beater driveline is activated, the maintenance-free clutch engages, the drive belt starts softly and unloading begins.

The components are protected and a long service life guaranteed.



Loading rotor

75% of the rotor's width is fitted with a new high-strength case-hardened steel which ensures high wear resistance in areas subjected to a lot of wear. This increases service life by 25%.



Scrapers

Each of the scrapers in the loading chamber has an 18-mm-wide backing. The unique enormous scraper surface of 53% of the overall surface ensures best possible crop retention in the loading chamber.

The crop is cleanly scraped off the rotor and is not drawn in: it stays in the loading chamber:

This allows a high degree of compaction in the loading chamber if need be, which increases the cost effectiveness even when field to farm distances are long.

The scrapers are made of wear-resistant Hardox which gives you the longest possible service life.

Transfer throat

The transfer throat has been widened by 100 mm, thereby allowing even greater throughput than its predecessor.

It guarantees a high level of efficiency during chopping and allows shorter chopped length at edge than other, wider commercially available loading systems.

Rear panel

The chopping unit rear wall on the JUMBO consists of wear-resistant fine-grained steel. This greatly increases the service life.

Efficiency and high output



Rapid unloading

The JUMBO's excellent unloading performance makes it an efficient team player in any silage convoy. Its unloading speed of up to 35 m/min prevents vehicles used for rolling having to wait in the clamp.

Efficient unloading

Rapid unloading, a perfect blanket of unloaded material and as little work left to do by the rollers as possible – the JUMBO's beater driveline makes it possible.

Unloading performance has been increased by a further 33%. With total power output of 210 kW the beater driveline allows unloading times of less than a minute. This means that JUMBO models with a beater system have an output equal to those with no beaters.

The innovative form of beater rotor with V-twist work the crop evenly and with no power peaks. They reliably loosen even highly compacted forage. This saves energy and results in optimum efficiency with reduced wear. The beater drive switch integrated into the angular gearbox

is activated by the belt tensioner to ensure friction-locked startup.

The soft start protects not just the beater driveline elements but also the scraper floor drive and the chains. No power peaks occur and the service life is prolonged.

If the selected feed speed is too high the scraper floor automatically slows down.

Should an overload occur, a cam-type clutch protects the beater driveline.

The soft start means that unloading can be paused, enabling the crop to be split as it is unloaded in the clamp.

The evenly spread blanket of forage on the JUMBO facilitates the rollers' work, thereby guaranteeing efficient compaction and the best silage quality.



Conical configuration

The loading area on the JUMBO has a conical form. On each side it opens out 25 mm to the rear. This keeps friction to a minimum during unloading. The loaded crop is released more quickly and the scraper floor speed can be increased earlier. This helps rapid unloading even when field to farm distances are long and the crop has settled.



Lowered scraper floor

The scraper floor has been lowered by 250 mm. This reduces the amount of power required for loading. The higher forage package that goes along with this also allows increased compaction and the wagon increases its net load capacity.

As loading begins, a compact and stable forage block forms at the front panel. This is subsequently pulled continually backwards by the scraper floor.

The high-strength steel floor consists of panels and forms a strong loading area with minimal friction coefficients for rapid unloading.



Flat link chains

The wide flat link chains with a breaking load of 13 t provide great stability, maximum reliability and smooth running.

The scraper floor slats are double-bolted and rest on exchangeable guide bars.

Its high power transmission and robust construction make the JUMBO suitable for transporting all kinds of chopped material.



Scraper floor drives

Two high-performance drives with integrated 2-speed switching are integrated in the longitudinal bar.

The patented boost function ensures that all the tractor's available hydraulic power is used.

The highest forage quality



The highest forage quality

High yield dairy cattle need a high quality basic ration with the optimum forage structure.

When developing the JUMBO the primary objectives were clean and gentle forage collection, a short and even chop, loading forage and avoiding needless wastage of forage and power by ensuring a high output.

The new hydraulically driven, controlled floating pick-up with the new jockey wheel linkage, additional tracking roller, new drive concept, new rotor, chopping system and movable front panel. These developments are all the result of our listening to our customers and faithfully meeting their requirements.

Perfect chopping quality

In addition to the great importance of the optimum dry matter content, the chopped length of the forage has a significant influence on the quality of the grass silage. This reduces the rumination time and makes it easier for the rumen to process.

Both parameters lead to faster pH reduction, which reduces the risk of fermentation errors and has a positive effect on the stability of the grass silage. This lays the foundation for high dry matter intake.

34 mm chopped length

The JUMBO is the ideal choice for the highest forage quality thanks to the short-chop knife bank with a theoretical chopped length of 34 mm.

The long arc of the knives ensures a slicing cut along the full length of the knife edge. The forage is chopped right through exactly and uniformly and as a result has the optimum structure for ruminants.



Clean pick-up

The pick-up tines on the JUMBO are controlled in a sweeping arc. This guarantees best possible sward protection and low crude ash ingress. Additionally, the speed is adapted to prevent needless tine wear. The interaction of the controlled pick-up with the floating pick-up suspension and the low pressure on the ground result in the cleanest possible collection of the crop. This ensures the contamination level is within the limit values of 80–100 g/kg of dry matter.

1% less crude ash at a yield of 7,500 kg DM/ha yields 300–350 litres more milch.

With grass silage, a 1% increase in crude ash/kg DM translates into a reduction in energy concentration in the forage of approx. 0.1 MJ NEL/kg DM.

Our customers place great value on the highest quality forage.

"When it comes to loader wagons, we place particular emphasis on the chopping quality. The wagon has to deliver top chopping system performance and the new JUMBO gives us exactly that.

The hydraulically driven, controlled pick-up is a very good solution from my point of view, because you can regulate the pick-up speed depending on the driving speed. This prevents the forage from being dragged through so that it passes into the rotor parallel to the knives.

The loader wagon's loading system also contributes to good forage quality. That's why we use the optimised automatic loading system to make sure the forage in the loader wagon isn't compressed too hard or too little."

Jeff Reiff
Farmer & Contractor
Troisvierges | Luxembourg

The highest forage quality



- 1 Hydraulic drive
- 2 Cam track control
- 3 Actively driven feed augers
- 4 Selectable jockey wheel linkage



Controlled floating pick-up

The 7-row floating pick-up with a working width of 2,300 mm according to DIN ensures maximum intake. The JUMBO's pick-up delivers clean and tidy collection without losses in a single pass.

Hydraulic drive

The speed adapts automatically to the travelling speed in a range of 75 to 125 rpm.

Cam track control

Best quality forage is guaranteed not just by great reliability but also by cam track control. Compared to other commercially available systems, it allows significantly greater floating and can be used at markedly lower speeds.

Actively driven feed augers

The feed augers deliver optimum crop flow even at high travelling speeds. The transfer throat is filled with maximum efficiency, thus increasing chopping quality.

Ground tracking

Large arc of movement of $\pm 3.5^\circ$ corresponds to an arc of movement of 120 mm at the outer tine. The central suspension of the pick-up support frame and the two guide arms, one on each side, ensure perfect ground tracking.

Selectable jockey wheel linkage

The jockey wheel linkage can be adjusted depending on the application. You decide whether the pick-up should be coupled indirectly or directly.

Additional tracking roller

The additional tracking roller prevents the pick-up wheel from sinking into tractor wheel marks and enables unrestricted movement for best ground tracking.

The highest forage quality



Neat, safe and convenient

The JUMBO's wide pick-up combines clean and tidy collection without losses in a single pass with a supremely comfortable ride. It is suspended in the centre and controlled from both ends by a steel cam track. The enormous pick-up width of 2,300 mm according to DIN means that no swath is too wide. Thanks to the extremely high loading performance even swaths placed by a self-propelled harvester are cleanly picked up.

The large working width also makes driving into the swath and cornering easier, which takes the pressure off the driver.

Perfect ground tracking

Regardless of the terrain in which you use your JUMBO, the floating pick-up adapts perfectly to the ground contours and protects the crop against contamination.

Hydraulic adjustable weight alleviation reduces pressure on the ground to approx. 100 kg, allowing the pick-up to float over the ground.

The optional pick-up jockey wheel chassis with floating function features a patented parallel linkage for unique ground tracking.

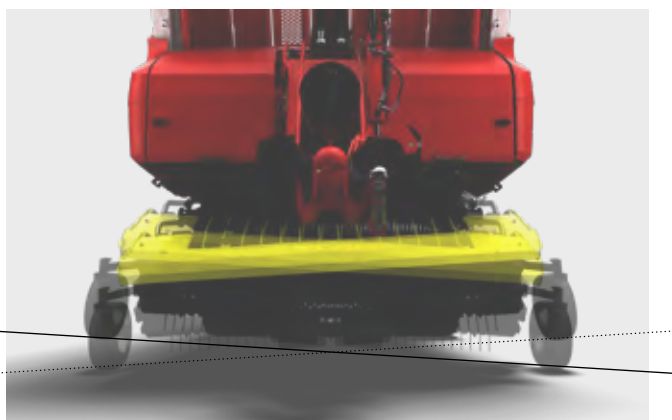

120 mm floating pick-up

With its unique 120 mm floating pick-up, the JUMBO ensures perfect ground tracking and exact contouring. The floating function allows you to collect the cleanest possible forage, even in difficult terrain.



Trailing jockey wheels

Standard

The standard trailing jockey wheels are implemented as rigid to guide the pick-up cleanly over every bump in the ground.

Outside width: 2.99 m

Hydraulically folding

To help drivers when access to a field is narrow the jockey wheels can optionally be folded in hydraulically from the control terminal.

The hydraulically folding trailing jockey wheel reduces the transport width to an outside dimension of 2.55 m.

Jockey wheel linkage

The standard trailing jockey wheels feature two jockey wheel linkages. This allows you to make adjustments to suit your particular set-up.

- 1** Pin-in-hole position "indirect"
The raised jockey wheel is held at the same height as the pick-up tines, providing greater ground clearance.
- 2** Pin-in-hole position "direct"
The jockey wheel transfers every movement directly (1:1) to the pick-up drum. This significantly improves ground tracking.

Jockey wheel chassis

The optional additional tracking roller prevents the pick-up sinking into tractor wheel marks. It is located on the centreline behind the pick-up and covers a wide area of ground thanks to its generous dimensions. Together with the two jockey wheels, the wide additional tracking roller forms a strong support triangle for perfect ground tracking. This considerably reduces the tines scraping the soil so contamination of the forage is avoided.

The additional tracking roller also guarantees clean forage collection in hilly terrain.

The highest forage quality



Hydraulic drive

The JUMBO pick-up's new hydraulically adjustable drive system adjusts the speed automatically to the travelling speed. This ensures clean collection without dragging the forage through in the direction of travel.

This adaptation of the speed reduces crude ash ingress and protects the pick-up tines.

The speed signal is received via the tractor's ISOBUS signal, the tractor's InCab port or direct from the loader wagon using an electronic brake system, electronic steered axles or intelligent trailed axles.

Pick-up speed is between 75 and 125 rpm. In automatic mode the pick-up regulates the speed independently. At a driving speed under 10 kph the speed is only 75 rpm. It increases as loading speed increases.

In manual mode the desired speed can be set individually.

Drawbar load compensation

To compensate for the reducing size of the opening cross-section between the pick-up and the drawbar during loading, the JUMBO automatically adjusts it.

The automatic control adjusts the parallel lift drawbar to the set position every 10 seconds, ensuring maximum throughput during the entire loading process.



Cam track

The shape of the cam track ensures optimum movement of the tines.

The tines, which are controlled in a sweeping arc, will only take up crop at the correct angle if they are guided by a cam track. They convey the crop gently upwards and actively transfer it to the rotor at a suitable speed.

The tine subsequently dips down at a right angle to prevent the forage from being drawn in.



Tines

The optimised DURASTAR pick-up tines with a wire thickness of 6 mm enable a 20% longer service life with consistently high collection quality. This cuts wear costs.



Feed augers

Large diameter feed augers on each side actively merge the swaths. The compact swath is evenly distributed across the full width of the transfer throat as it is fed to the rotor. That is how the JUMBO achieves the best short chopping quality.



Handling trolley

For optimum maintenance and service access, the pick-up, with a rigid jockey wheel, can be placed on and removed from a handling trolley which is available as an option.

Removing the pick-up can reduce the JUMBO's weight by approx. 520 kg for transport mode. This considerably increases the net load capacity. Combining it with an optional additional tracking roller can even save as much as 580 kg.

Removing the pick-up when the JUMBO is used purely for transport purposes also prevents it from being damaged.

The highest forage quality

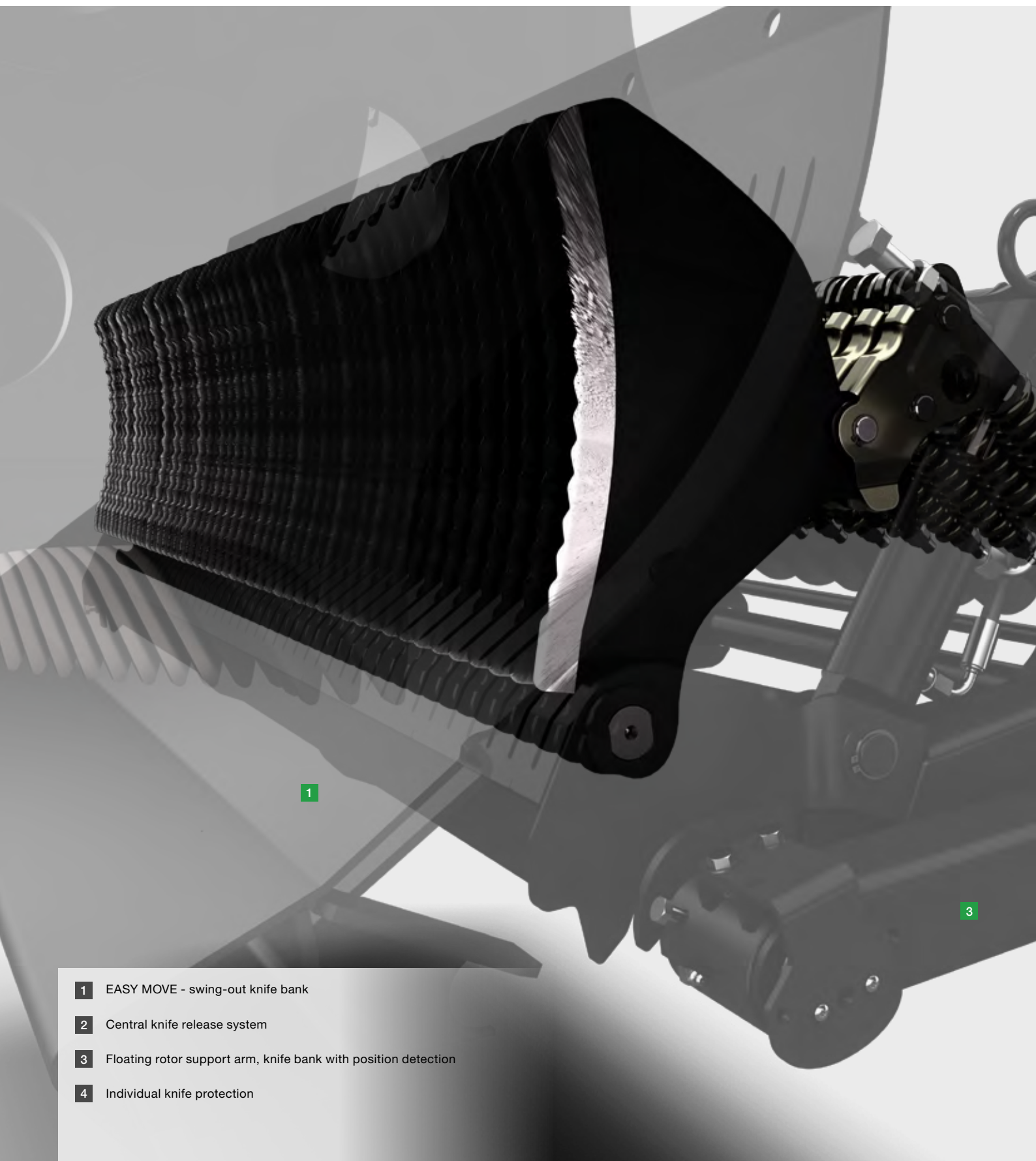

1

3

- 1 EASY MOVE - swing-out knife bank
- 2 Central knife release system
- 3 Floating rotor support arm, knife bank with position detection
- 4 Individual knife protection

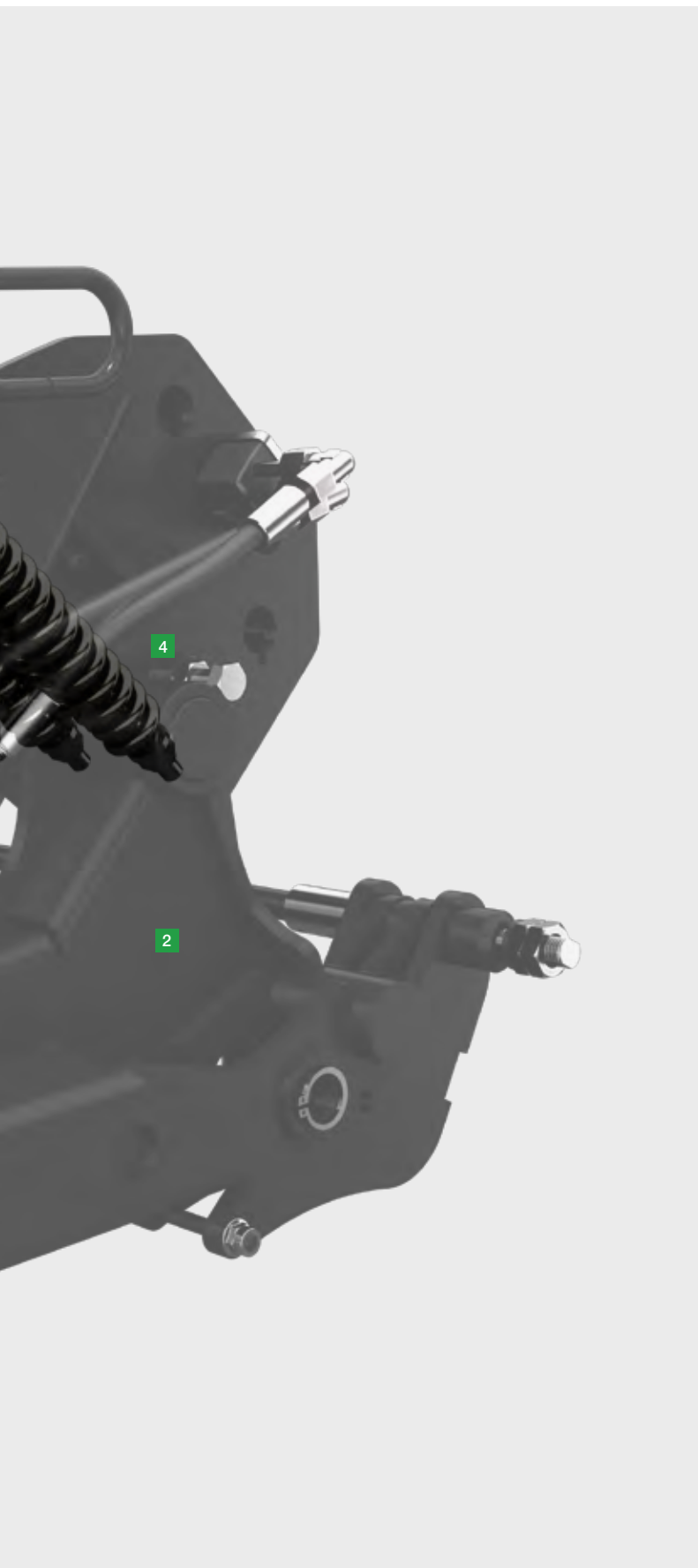

34 mm chopped length

The tried-and-tested POWERCUT short-chop knife bank makes the JUMBO first choice for highest forage quality. The asymmetrical configuration of the 48 knives ensures even smoother running than before.

EASY MOVE

For maximum operating convenience and easy servicing. The knife bank requires no tools and pivots out to the sides.

Central knife release system

The push-button hydraulic central knife release system allows rapid knife replacement without the need for tools.

Patented individual knife protection system

The knife protection system is operated by a trigger mechanism and provides double protection: the knife is first damped and then swung out of the interlock. Afterwards it is automatically returned to its original position.

AUTOCUT

Fully automatic knife sharpening system with electro-hydraulic drive system.

Chopped length distribution^{*)} of the 34 mm short chop knife bank

Stalk length frequency distribution as a percentage of each chopped length range:

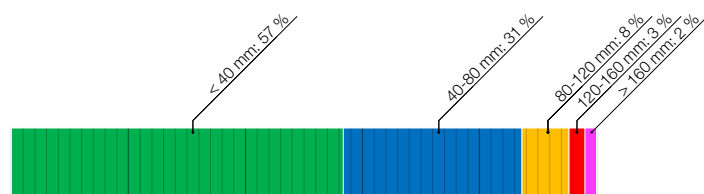

^{*)}Source: Study by Josephinum Research 2017

The highest forage quality



EASY MOVE swing-out knife bank

This unique swing-out knife bank makes light work of changing and turning the knives.

Press the button on the side of the wagon to swing the knife bank out. The knives simply swivel out after the mechanical safety interlock is released.

Servicing is then safe and easy to perform from the side.

A central hydraulic knife release system is standard. Simply press the release button to disengage the knives so they can easily be removed without the need for tools.

Simply convenient

EASY MOVE lets you change or turn the knives simply and safely outside the loader wagon.

It allows you to carry out servicing and inspection ergonomically.

Thanks to this comfortable way of working, knives are checked more often and the loader wagon is always in peak operating condition.

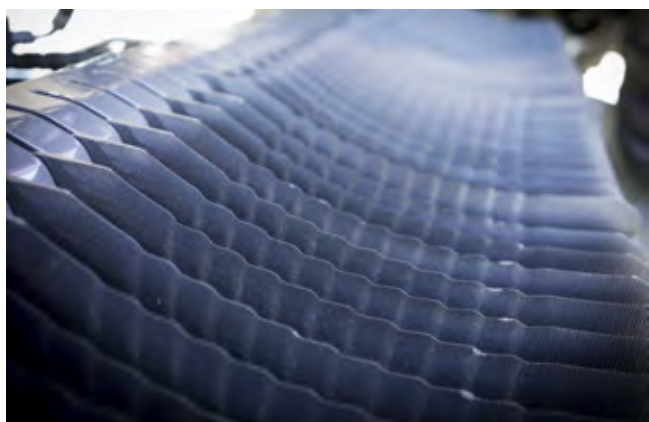

Knife quality

The knives are designed for optimum throughput and made of hardened DURASTAR tool steel. The serrated edge ensures a consistent and precise chop. The extra thick rear edge of the knife guarantees maximum reliability.



Individual knife protection

PÖTTINGER protects your loader wagon with our patented individual knife protection system. Foreign objects are a danger to your livestock and the loader wagon. Moreover, downtimes are costly and reduce the quality of the forage.

The triggering force of the knife protection system is adapted to the high throughput capacity. The knives are held in the correct position to make sure that they chop consistently. The knife retention springs and rollers on the individual knife protection system are swung safely out of the way. This greatly reduces the contamination of the knife holders.

- 1 Foreign objects trigger the protection system. The knife moves in the direction of crop flow.
- 2 The trigger roller is lifted out of its holder behind the knife.
- 3 The resistance of the knife is suddenly reduced so that the knife can allow the foreign object to pass through.
- 4 The knife is then automatically returned to its original position.

Any stones in the forage are not pulverised. The livestock leave the foreign objects untouched in the trough, thus preventing injuries to the digestive tract.

TWIN BLADE

Turn, don't change with the optional TWIN BLADE DURASTAR reversible knife. Its new and patented shape gives you double the service life. With TWIN BLADE you have a fresh blade to hand without needing to sharpen the knives or to have a second set with you.

The highest forage quality



AUTOCUT - fully automatic knife sharpening system

A precise and consistent chop is the basis for the best silage quality. AUTOCUT ensures that you and your customer have chopping quality that remains consistently high all day long.

Only really sharp knives can guarantee optimum chopping quality, lower power consumption and increased output. The AUTOCUT knife sharpening system is a convenient way of sharpening the knives fully automatically on the loader wagon itself.

The number of sharpening cycles can easily be preset using the control pad, depending on the wear on the knife.

You can reduce fuel consumption by up to 15% by using knives that are always sharp.

Maintenance work is reduced by about 45 minutes per day, because automatic sharpening can take place during a break.

Electro-hydraulic drive system

The AUTOCUT on the JUMBO now has an electro-hydraulic drive system which significantly reduces sharpening times.

The sharpening procedures can be individually adapted to what is required for the job in hand. The sharpening head can be adjusted in three dimensions for perfect conformity with the knife shape.



Simple operation

- 1 All knife functions and the parallel lift drawbar can be operated from the standard control panel on the side of the wagon.
- 2 All AUTOCUT functions are operated using the additional control terminal.

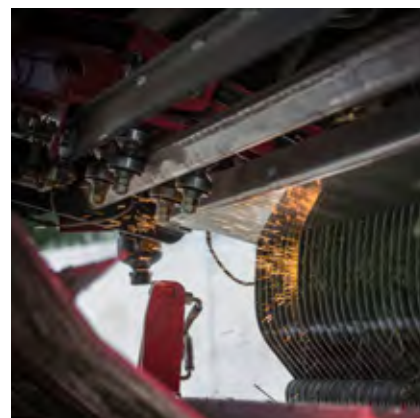
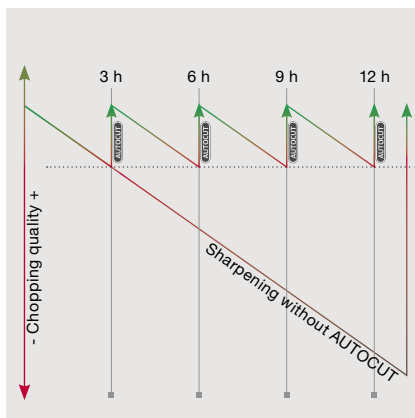

Less servicing

AUTOCUT sharpens the complete set of knives fully automatically in next to no time.

The number of sharpening cycles can be selected on the control terminal depending on the level of wear.

AUTOCUT reduces your maintenance work by up to 45 minutes per day.

AUTOCUT advantages

- Knives always sharp
- Greatly reduced maintenance requirement
- Fully automatic sharpening of the complete set of knives at the press of a button
- Sharpening head adjustable in two dimensions
- Sharpening intensity can be regulated as needed
- Even wear on all knives

Increase profit with sharp knives

"The quality of the cut is important so that you can compress the grass to expel all the air. If I have silage with a high protein and energy content, then I can expect to obtain a high milk yield and only need small quantities of additives - that is what makes production much more efficient."

Hans-Willi Thelen
Organic dairy farmer and
TPS contractors
Kall | Germany

The highest forage quality



Moveable front panel

The moveable front panel is standard and provides significantly more volume with the same length of wagon. It increases loading volume by 4.3 m³.

At the design stage, particular attention was paid to ensuring that the operator has a good view inside the loading chamber.

The front panel makes the loader wagon significantly more compact so that manoeuvrability is improved even in small spaces and on narrow tracks.

Optimised load distribution over the axle load and drawbar load ensures stable and safe handling on both the field and the road.

The moveable front panel also serves to support unloading. The block of forage is pushed to the back and automatically overturned soon after the scraper floor starts up.

Automatic loading

The standard automatic loading system supports the driver with loading and provides a high level of convenience. To guarantee the best possible working results, two modes are available.

- Loading torque measurement at the belt drive
- Measuring point on the moveable upper forage compression flap.

Choose loading torque measurement at the belt drive for best results with damp forage because the block of forage cannot reach the compression flap.

The more frequently selected option is the one with the measuring point in the moveable upper forage compression flap.

This is designed for classic wilted silage and allows easy and immediate adjustment of scraper floor switchpoints and running times to particular crop conditions and filling criteria.



Automatic loading

The standard automatic loading system is designed for continual automatic filling of the loader wagon, even on long harvesting days, thereby easing the driver's workload.

- 1 Loading torque sensor
- 2 Compression flap sensor



Standard front panel

On the standard model, the moveable front panel allows significantly higher volume.

The automatic loading system can be adjusted depending on the type of forage and its dry matter content. When unloading, the front panel supports rapid and effective filling.

Loading position

The front panel is in the upright loading position. The upper forage compression flap is preloaded by a spring. 730 mm long and 2,300 mm wide, it offers a large surface area which also allows crop to fill up well, even along the sides.

End position

When the wagon full signal comes from the rear panel, the front panel pivots forward to its end position independently of the automatic loading system, making full loading capacity available.

The highest forage quality



Intelligent front panel

The patented, intelligent and automatically controlled front panel enables a unique loading and unloading strategy. Available as an option, its length of 830 mm means it has a particularly generously dimensioned upper forage compression flap.

An additional dynamometer bolt is fitted in the intelligent front panel to enable a new control concept. These measure the loading pressure at the front panel. With the combination of all measuring points (loading torque sensor, dynamometer bolt, compression flap sensor), the degree of compaction and the desired filling level can be directly regulated. As a result, the parameters can be perfectly adjusted to your forage collection requirements.

With the active forage compression flap, unique loading rates of up to 400 kg/m³ can be achieved if required, depending on the DM content.

Intelligent loading system

Three predefined modes can be selected for loading. They enable optimum adaptation to different types of crop, the dry matter content and the degree of filling.

- Mode 1: Light load
- Mode 2: Medium compaction
- Mode 3: High compaction

These three modes can also be individually adjusted to suit your requirements.

Active forage compression flap

The active upper forage compression flap is another highlight. It regulates the loading pressure and the filling rate and guarantees the highest quality forage.

The control system offers fast and direct adaptation to changing operating conditions.



Filling strategies

Depending on the job in hand and the requirements, the three modes can be selected for the most suitable filling strategy. You can programme each strategy with predefined parameters, this vastly improves the overall cost effectiveness of the tractor and wagon combination.

- 1 Loading torque sensor
- 2 Compression flap sensor
- 3 Dynamometer bolt

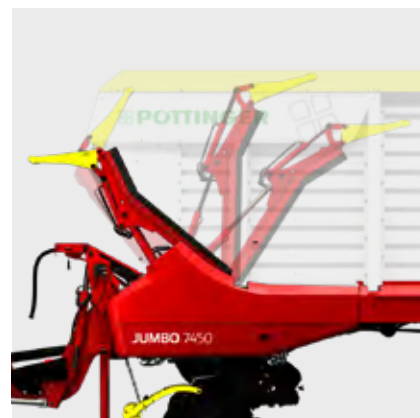

Loader wagon mode

If the scraper floor is actuated by the automatic loading system, the front panel helps push the forage along and then automatically moves back into the loading position. This patented control system ensures that the forage stays extremely compact.

After reaching the full signal, the front panel pivots forward in three steps. In the process, residual filling is activated and controlled under pressure.

In addition, the intelligent front panel ensures perfect and maximum filling.

Unload in record time

During loading, the front panel also pivots. It transfers the entire crop to the scraper floor and actively pushes it towards the rear.

The combination of the scraper floor's patented hydraulic boost function and the pushing action of the front panel, ensure that even the biggest JUMBO unloads in less than a minute.

Harvest transport mode

In transport mode, only all transport-relevant functions are displayed in the Work menu. In this mode, the JUMBO is driven just like a transport wagon.

To give the operator a clear view from the tractor into the loading chamber or for driving under the harvester, the compression flap can be hydraulically folded forwards.

Due to the extremely low pivot point of the flap, you have the best view of the chopped material.

An optional load containment system is recommended for transport on the road.

Reliability



Maximum reliability

Today, ever larger areas are expected to be covered in ever shorter harvest windows. That is why it is more important than ever to have machinery you can really rely on.

To aid this,, the JUMBO has been designed for maximum reliability. One of the greatest challenges here is to ensure clean crop collection under all operating conditions and throughout the entire season.

The tine control ensures a longer active conveyor effect right up to the withdrawal point. This ensures the forage is transferred to the rotor perfectly.

Thanks to the reduced speed of the rotor, the forage is not “dragged through”. The existing alignment of stalks in the swath is retained, transferred 1:1 to the rotor and guarantees the best possible chopping quality.

Safely through all operating conditions

The 7 row pick-up is controlled from both ends by a steel cam track.

Its tines are slightly trailed to sweep in a controlled arc. The pick-up’s hydraulic driveline automatically adjusts the speed to the travelling speed or can be adjusted manually.

This guarantees maximum performance at high travelling speeds, as well as constant intake.

The JUMBO delivers reliable crop harvesting under all kinds of operating conditions, whether the crop is wilted silage, wet silage (< 30% DM), whole crop or straw.



Reliable and dependable

As soon as the large rotor with its optimised tine contour has taken up the forage from the pick-up, it transfers it gently through the 34 mm short-chop knife bank.

Should foreign objects enter the crop flow the patented individual knife protection system lets them pass through and automatically returns the knife to the starting position. This ensures that the loader wagon and knives are effectively protected against damage and costly downtimes are avoided.

We need powerful and reliable machines

The peninsula of Brittany has an oceanic climate which is very good for growing grass, but is not always easy for harvesting. With regular rainfall at all times of the year, we need to be able to depend on reliable equipment that is highly efficient in all conditions.

The new belt drive concept with loading torque sensor makes it possible to operate the JUMBO at maximum power at all times. The durability of the equipment depends a lot on how it is used, "I wanted the loader wagon to be able to constantly monitor the torque itself so that the driver is less fatigued."

Yann FAUJOUR
Contractor
Brittany | France

Reliability



Ongoing development

PÖTTINGER constantly invests in research and development so that the product portfolio is continually improved.

Constant expansion of our own test centre, the heart of our quality assurance policy, also plays a vital role in this.

Our test centre, housed at the TIZ (Technology and Innovation Centre), is one of the most modern in agricultural technology worldwide. We test the durability and performance of essential components and machinery there.

High quality components

Apart from field trials, the new components of this JUMBO generation were also put through their paces and their service lives tested before they received the “seal of approval”. The stress and strain exerted on the entire drive train in the field was recorded during test runs with sensors attached to critical points and was then analysed in the test program. During the trials, the target of 8,000 loader wagon loads with no malfunction was not just achieved, but exceeded.

This new generation therefore stands apart with its maximum fail-safe factor, reliability, cost effectiveness and low wear costs. This also ensures high value retention beyond the machinery's service life.

Electronics

The new control unit 3.0 with standardised automotive casing and modular cable harness without terminal box reduces susceptibility to malfunctions by using fewer exposed connections.



Steering systems for greater safety

For greater driver comfort on the road and in the field, you can equip your JUMBO with a number of different steering systems.



Hydraulic steered axles

The hydraulic steered axles guarantee absolute reliability and excellent tracking and protect the sensitive sward.

They have a track rod with a K50 ball head coupling. Thanks to the telescoping automatic interlock, the loader wagon can easily be removed by only one person.

The coupling point for the steered axles on the tractor according to ISO DIN 26402 is based on the K80 ball head coupling as a backlash free towing device. This guarantees precise tracking even on steep ground and in the clamp.

Electronic steered axles

A high level of stability when driving at high speeds and the best manoeuvrability in tight corners are provided by the speed-dependent steering angle adjustment system of the electronic steered axles.

- In the field, a tighter turning angle produces greater manoeuvrability and protects the ground
- At high driving speeds, less of a turning angle ensures a higher level of safety

A safety steering computer controls the turning angle together with a hydraulic unit, the steering cylinders and an angle sensor on the steered axle.

Intelligent trailed axles

With the "intelligent trailed axles" driver assist system, the loader wagon autonomously detects the movement. It allows automatic axle locking under all operating conditions even without a speed signal from the tractor.

A direction-of-rotation sensor detects the speed of forward and backward travel and locks the axle within the speed range you have previously defined.

The inclination sensor also locks the axle when the defined inclination is reached.

If the defined inclination value is exceeded, you can also have a warning displayed on the control terminal screen.

Reliability



Conserves soil

Always look after the health of your soil. Choose the right tyres, protect the sward, and you will increase your profits.

With the right tyres, there is no contradiction between using high output technology and conserving the soil. In order to protect soil as a natural resource, to ensure sustainable soil fertility and to maintain soil performance, you need to make sure that loads are distributed uniformly. Using the largest possible dimension of wheels increases the footprint of the tyres so that the soil structure is maintained in the best possible way.

- 1 cm deep wheel marks cost up to 10% more diesel¹⁾.
- Damage to the sward can cause yield losses amounting to €100/ha¹⁾.
- Heavy compaction can result in fertiliser costs up to 20% higher¹⁾.

JUMBO tyre chart 7380/7400 with an axle load of 9 or 10 t at 40 kph

Tyre size	Payload per wheel	Tyre pressure	Footprint	Pressure on ground
710/50-R26.5 885	4,500 kg	-	-	-
	5,000 kg	-	-	-
710/50-R26.5 Country King ³⁾	4,500 kg	1.7 kPa	2,574 cm ²	1.75 kg/cm ²
	5,000 kg	2.6 kPa	2,132 cm ²	2.35 kg/cm ²
710/50-R26.5 Flotation Trac ²⁾	4,500 kg	1.5 kPa	2,794 cm ²	1.58 kg/cm ²
	5,000 kg	1.7 kPa	2,822 cm ²	1.74 kg/cm ²
710/50-R30.5 Flotation Trac ²⁾	5,000 kg	1.9 kPa	2,524 cm ²	1.94 kg/cm ²
800/45-R26.5 885	4,500 kg	-	-	-
	5,000 kg	-	-	-
800/45-R26.5 Country King ³⁾	4,500 kg	1.5 kPa	2,920 cm ²	1.54 kg/cm ²
	5,000 kg	1.9 kPa	2,956 cm ²	1.69 kg/cm ²
800/45-R26.5 Flotation Trac ²⁾	4,500 kg	1.4 kPa	2,930 cm ²	1.51 kg/cm ²
	5,000 kg	1.6 kPa	2,954 cm ²	1.66 kg/cm ²
800/45-R30.5 Flotation Trac ²⁾	5,000 kg	1.6 kPa	2,944 cm ²	1.67 kg/cm ²

¹⁾ Source: Lecture by Southwest Falia Agricultural College in Soest, 2008.

²⁾ Source: Apollo Vredestein GmbH; ³⁾ Source: Nokian Tyres



Parabolic spring chassis 26.5"

The compensator arm on the parabolic leaf spring chassis ensures the load is distributed dynamically especially when braking so the same load acts on each wheel and excellent deceleration values are achieved.

With an axle compensation of 110 mm the chassis has perfect suspension characteristics in the clamp and provides smooth running in the field and on the road.

The trailed axles protect the sward even with heavy loads (standard).

A large spring support spacing of 1,100 mm at the front rigid axle with a distance of 856 mm on the rear steered axle provides perfect stability. Strong longitudinal linkages apply the braking and steering force.

Anti roll bar

The anti roll bar gives you 20% greater driving stability, best possible load distribution and better handling on steep ground and when cornering. A torsion bar on each axle connects the springs on each end to the chassis frame. When loads act on it the bar transfers the pressure automatically to the opposite end.

Optional

- Hydraulic steered axles
- Electronic steered axles
- Intelligent trailed axles driver assist system
- EBS - electronic braking system with RSP - roll stability program

	Tandem chassis with parabolic spring 18 t, 26.5"	Tandem chassis, hydraulic 20 t, 26.5"	Tandem chassis, hydraulic 20 t, 30.5"	Tridem chassis, hydraulic 27 t, 26.5"	Tridem chassis, hydraulic 30 t, 26.5"	Tridem chassis, hydraulic 30 t, 30.5"
JUMBO 7380 DB	■	□	□	-	-	-
JUMBO 7400	■	□	□	-	-	-
JUMBO 7450 DB	-	■	□	□	-	-
JUMBO 7470	-	■	□	□	-	-
JUMBO 7520 DB	-	-	-	-	■	□
JUMBO 7540	-	-	-	-	■	□

■ = Standard, □ = Optional

Reliability



Hydro-pneumatic chassis

The hydro-pneumatic chassis gives you a wide support spacing for safe handling, exceptional stability on steep ground as well as enhanced safety when driving at high speeds.

An impressive increase in driving comfort has been achieved by fine-tuning the suspension characteristics. Using a different hydraulic accumulator when the loader wagon is empty from the one when the wagon is full noticeably increases driving comfort.

The chassis with hydro-pneumatic suspension developed by PÖTTINGER absorbs shock loads in the field and on the road. Consequently, it provides markedly greater shock-absorbing comfort than rigid systems that only use tyre suspension.

In addition, the tyres are subjected to less wear and the machine follows smoothly in the tractor's tracks.

The large axle compensation of up to 270 mm ensures better climbing ability on inclines, in the clamp and on poor quality roads.

- Standard leaf spring suspension
- Wide support of the guide springs with anti roll bar effect – wide support spacings of 1,100 mm and 856 mm.
- Excellent roll or slope stability due to minimal deflection
- Highest level of driving comfort in traffic and off-road
- Optimum braking power thanks to equal axle load distribution

The entire vehicle is designed in accordance with the latest provisions of EU type approval.



Stable on steep ground

Instead of relying on a complicated and sluggish hydraulically engaged slope compensation, the JUMBO uses mechanics to guarantee an immediate response.

The unique mechanical anti roll bar effect is achieved by integration of longitudinal linkage springs on the chassis, the bolted connection of the axles and the wide spring spacing.



Compensation

The hydro-pneumatic axle compensation ensures uniform wheel pressure in all operating situations. In particular, less pulling power is needed when driving away from a silo plant.

It is also the best way of maximising the loader wagon's climbing ability.

Suspension

Especially when loading up to 20 t of crop and driving at up to 65 kph, top quality vehicle suspension that functions reliably whatever the load status is crucial.

What makes this chassis special is the fine-tuning of suspension characteristics when the wagon is empty or full.

The result is supremely smooth running, a comfortable ride and not least greater safety when driving.

Ground clearance

The JUMBO is a hugely versatile multi-purpose rotor loader wagon that can be deployed in all conditions including difficult terrain.

When developing the brake system particular attention was paid to greatest possible ground clearance.

All essential brake components are located above the axle centreline. This ensures that they are well protected and will work reliably.

Reliability



Tandem chassis

With the hydro-pneumatic tandem chassis, an axle load of 20 t and overall weight of 24 t are possible. To reduce rolling resistance still further, 30.5" diameter tyres can be mounted as an option. Compared to 26.5" ground pressure is marginally reduced.

With 800/45-R26.5 ground pressure per axle is 1.66 kg/cm³ *) and with 800/45-R30.5 1.67 kg/cm³ *).

The trailed axles protect the sward even with heavy loads (standard).

The outstanding feature of this chassis is its tremendous manoeuvrability in the field.

Tridem chassis

The hydro-pneumatic tridem chassis distributes heavy axle loads of 27/30 t over a large surface area.

The JUMBO 7470:

The third axle increases the net payload by 50%. At the same time it reduces transport costs by up to 25% depending on deployment time and duration. Compared to the tandem chassis, ground pressure per axle is reduced by -10% from approx. 1.67 kg/cm³ *) to approx. 1.51 kg/cm³ *).

The tridem chassis is equipped with mechanical steered axles at both ends as standard.

Electronic steered axles (EZL) are available as an option.

*) Source: Apollo Vredestein GmbH



Weighing system

The JUMBO's optional weighing system is available for the hydro-pneumatic tandem and tridem chassis. It enables dynamic weighing as a rough guide while driving, and outputs exact¹⁾ measurements when parked.

If the maximum value defined by you is exceeded, a warning is displayed on the control terminal and an acoustic signal is given.

Electronic steered axles on the tridem

EZL steering programmes for tridem axle:

- Normal steering
- Crab steering
- Offset

Normal steering:

This programme is not always automatically activated. The steering angle is regulated according to speed.

Crab steering:

Sets the same steering angle for all steered axles.

Offset:

This special steering programme is used for anti roll compensation when driving on the slant.

Lift axle tridem

Minimises wear to the tyres when the wagon is empty.

In difficult terrain a lift axle can be deployed to temporarily increase the drawbar load and the tractor's traction.

A safety pressure valve automatically lowers the lift axle in the event of an overload to protect the tractor.

The system is operated conveniently from the control terminal.

¹⁾ Measuring tolerance +/- 2.5 %

Cost effectiveness



The cost effective process

A loader wagon can perform the tasks of crop collection, chopping, compaction and transport. That is why the loader wagon is often referred to as a two-person harvest system.

The JUMBO is a multi-purpose loader wagon that meets the requirements of a fully-fledged transport wagon. This means that it can be used for a multitude of tasks apart from grassland harvesting. This ensures high machine utilisation and maximises the efficiency of your JUMBO.

The loader wagon process guarantees the best quality forage and silage at low harvesting costs, making it the harvesting process of the future.

Better ensiling

It is in the silage process that the loader wagon really comes into its own. It can flexibly mix the areas to be harvested to generate a perfect mix of forage.

To give the vehicles used for rolling sufficient time for compaction, the JUMBO can combine field to farm distances and adjoining areas. This guarantees best quality silage and prevents downtimes in the entire harvest chain.

Because it achieves a high degree of compaction, up to 400 kg/m³, the JUMBO can transport far more crop than vehicles designed purely for transport. Transport with a JUMBO is therefore significantly more cost effective.



High output and cost-effectiveness are particularly important to us.

We run the new JUMBO 7470 with a Fendt 933 and can load 18 to 19 tonnes of silage with a dry matter content of 35%. It takes the same time to load as its predecessor, the JUMBO 6000, but the payload with the new JUMBO is 50% higher. So on a good day we can harvest up to 40 hectares.

We also like the JUMBO's wide pick-up and high loading speed. We can load at a driving speed of between 9 and 16 kph depending on the forage density, even if the swaths are high volume and irregular shapes. With the new JUMBO blockages are a thing of the past." Casa Carballo SAT Dairy farm
Pol - Lugo | Spain

Cost effectiveness



The all-rounder

With the JUMBO you have great flexibility, improved machine utilisation and, in consequence, maximum cost effectiveness.

You can also use the JUMBO as a robust transport and harvest transport wagon.

By using it to transport large loads of wood chip, maize silage, rye silage or biomass you can greatly increase the time that your JUMBO is in operation and so cut costs.

Removing the pick-up considerably increases transport capacity, quickly and easily.

As a highly productive loader wagon and harvest transport wagon, the JUMBO provides you with a true master of all trades.

Loading chamber expansion

By using 26.5" diameter tyres, loading chamber capacity can be increased by up to 2.6 m³ depending on the model. This makes full use of the legally permissible maximum overall height of 4 m and so increases cost effectiveness.

Load capacity expansion per model:

- JUMBO 7380/7400: + 2 m³
- JUMBO 7450/7470: + 2.3 m³
- JUMBO 7520/7540: + 2.6 m³



Load containment system

The newly designed loading chamber cover quickly covers the load and secures it ready for transport on the road.

The cover consists of two folding frame sections with a hydraulic chain hoist mounted on the shaft itself. The drive system is centrally mounted and compactly integrated in the wagon's superstructure so that it is well protected.

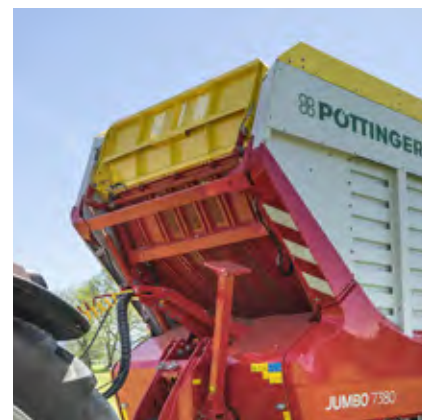

Duct cover

An optional duct cover prevents crop from falling into the rotor duct while the wagon is being used for transport. 2-part design for easy handling.

Removable pick-up

The optional handling trolley allows you to fit or remove the pick-up with rigid jockey wheels easily and in just 15 minutes.

This reduces the weight by up to 580 kg (pick-up incl. optional additional tracking roller). The payload is increased significantly.

If the pick-up has been removed, a rotor cover must be fitted as protection against contamination. The loader wagon can then be switched to transport mode.

The handling trolley also makes servicing easier.

Front panel

The new front panel provides 4.3 m³ more volume.

This means you get a loader wagon that is 1,350 mm shorter but has the same DIN volume.

As a result, the loader wagon is significantly more compact and even more versatile.

The higher net payloads increase cost effectiveness.

Convenience and maintenance



More convenience

Harvesting can mean a long day in the field, so it is all the more important to make your work with the loader wagon as smooth and enjoyable as possible. The practical automatic solutions on the JUMBO go a long way to helping you achieve this.

When the harvesting day begins with sharpened knives it may be advisable to sharpen the loader wagon's knives after only 2–4 hours. With AUTOCUT you always have a fully automated knife sharpening system at your fingertips. This guarantees you perfect chopping quality for as long as the working day lasts. When evening comes there is no need to remove the knives to sharpen them. AUTOCUT saves you an enormous amount of time.

Numerous automated functions support you in every operating situation.

The pick-up position control, a pick-up speed control, automatic transport and loading position, loading torque measurement, the intelligent front panel with loading and unloading strategies, the automatic unloading system and many other functions all make life more convenient for you so that you, the driver, are always relaxed and at the peak of your powers.

Less servicing

During development of the third JUMBO generation the topic of maintenance was very much in the spotlight.

- Number of gearboxes on board has been halved
- The front sprockets run on sealed bearings
- Rear scraper floor shaft bearings with central greasing points at the side

Service life at specific wear points such as the pick-up tines, the loading rotor, the knife steel quality, the rear panel and the scraper floor has been increased considerably.



Powerful sensor technology

The additional functions are made possible by the installation of sensors that measure position, speed and power.

An angle sensor for detecting the position of the pick-up and a speed sensor to control the hydraulic pick-up driveline help to harvest the forage conveniently and easily. A dynamometer bolt on the belt drive and the intelligent front panel support automated control of loading.

Our farm works well when our drivers are happy

"The new JUMBO is operated predominantly by a driver who has years of experience, and he always says: "This machine is really phenomenal." So he is enormously enthusiastic about it.

Previously he drove a JUMBO 6610 and 6620 and says: "The new JUMBO takes another big step forward - both in performance as well as ease of operation. We used the movable front panel to shift more weight onto the tractor on steep terrain." The new front panel also makes the loader wagon quick and easy to unload, which impresses all our drivers and our customers.

The automatic loading function works brilliantly too!"

Roland Kobler
Contractor | Agrolohn GmbH
Passau | Germany

Convenience and maintenance





Service counter

The driver is informed of forthcoming service intervals by a display on the control terminal.
If the service counter has expired, the Service data screen is displayed first next time you start the machine. This lets you easily keep track of upcoming service work.



Hydraulics concept

Thanks to the separation of hydraulics and electrics the loader wagon can be cleaned more easily and effectively.
The cables are arranged clearly, making it easier to detect faults and reduce downtimes.

Parallel function

The new hydraulic block facilitates simultaneous operation of several functions.
Pick-up driveline, scraper floor and front panel can be operated at the same time.

Convenience and maintenance





Lighting

The lights on the JUMBO have all been switched to LED, ensuring that the lamps have a long service life.

This saves money and reduces maintenance.

The powerful illumination provided by LED lights means you have light where you really need it.



Package 1 - Standard

- Loading chamber lighting with 4 LED strips

Package 2

- Loading chamber lighting with 4 LED strips
- 4 reversing floodlights
- 2 beacon lights and rear/brake lights at the top of the tailgate

Package 3

- Loading chamber lighting with 4 LED strips
- 4 reversing floodlights
- 2 beacon lights and rear/brake lights at the top of the tailgate
- 2 LED floodlights on top of the side panels
- 2 LED floodlights on the pick-up
- 2 LED floodlights as axle lighting
- 1 LED floodlight on the chopping system

Intelligent operation and ISOBUS terminal



A shared language

How machine and tractor communicate, even if they are from different manufacturers

Communicating in a common language is what stands behind the term ISOBUS. The need for this stemmed from the fact that each agricultural machinery manufacturer originally developed its own electronics solution. This was an obstacle for any farmer whose machinery consists of equipment from different manufacturers. ISOBUS refers to the standardised communication system between tractor and implement using standardised hardware and software that is not limited to a single manufacturer: This really makes your daily work a great deal easier.

More convenience using ISOBUS

ISOBUS eliminates isolated solutions by establishing a standardised, compatible connection between tractor and implement, which should work with all combinations using plug and play: Simply plug the ISOBUS plug into the ISOBUS socket and you are ready to go. A single ISOBUS terminal replaces the large number of implement-specific terminals inside the tractor cab.

Source: www.aef-online.org

The right solution for every requirement

A modern ISOBUS system consists of various components, including tractor, terminal and implement. It always depends on what the terminal and attachments are able to do in each situation - and what equipment options have been installed. This is where the ISOBUS functions come into play.

ISOBUS functions are independent modules or building blocks within the ISOBUS system. These work as soon as they are included in all the components involved.

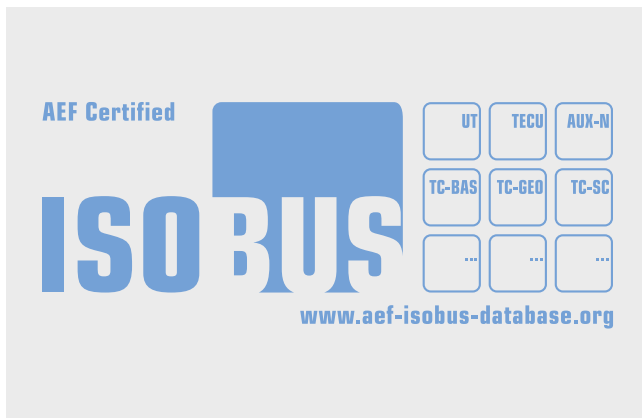

ISOBUS terminals

The EXPERT 75 and CCI 1200 ISOBUS terminals allow professional operation of all ISOBUS-compatible machines whether these were made by PÖTTINGER or other manufacturers.

Both terminals are AEF certified.



POWER CONTROL – electronic control system

Optional on JUMBO models.

The new entry-level POWER CONTROL terminal can be used to operate a wide selection of ISOBUS-capable machines made by PÖTTINGER. The most important feature is the keys that are printed with the relevant machine functions to ensure intuitive operation for both experienced and newbie drivers.

More functions can be controlled and user inputs made using the 5" colour touch display. Optimised for day and night operation, the display also provides clear information on the operating status of the machine.



EXPERT 75 ISOBUS terminal

Optional on JUMBO models.

The compact 5.6" EXPERT 75 ISOBUS terminal can be operated both directly via the touchscreen and using keys or a scroll wheel. Safe one-hand operation is supported by the grip bar. The ambient light sensor and the illumination of the function keys ensure convenient handling even at night.



CCI 1200 ISOBUS terminal

Optional on JUMBO models.

The new 12" CCI 1200 ISOBUS terminal offers the professional farmer a comprehensive function package. The terminal is operated like a tablet using a touchscreen. Navigation is kept simple so you find what you need with just a few taps. The terminal has a camera port. The integrated ambient light sensor automatically adjusts the brightness of the display.

Manufacturer-independent, wireless data exchange

Without agrirouter

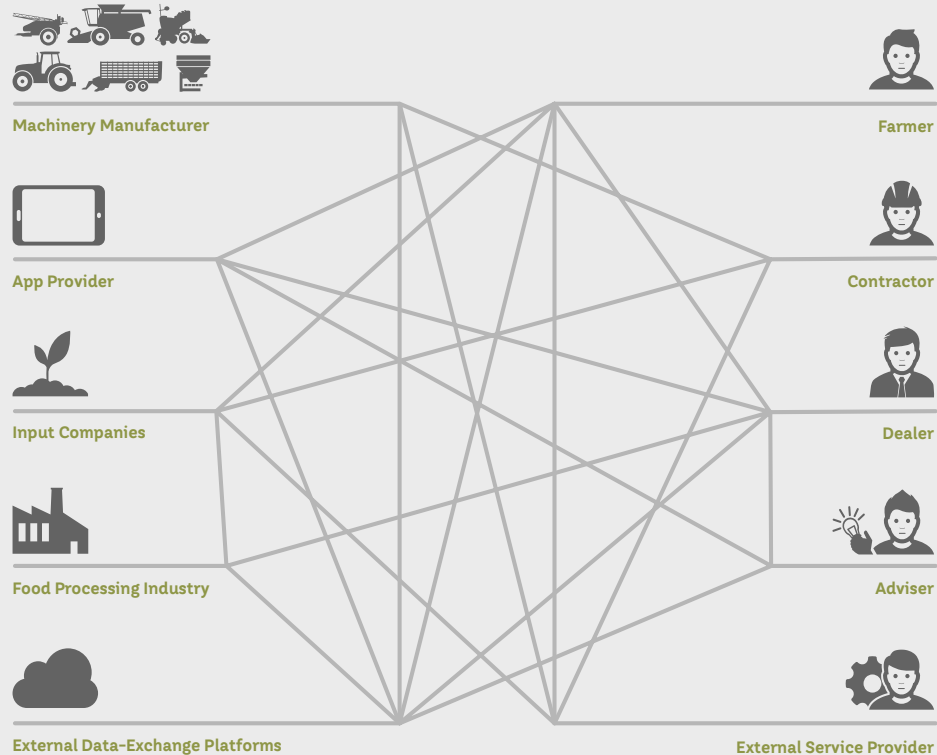

With agrirouter

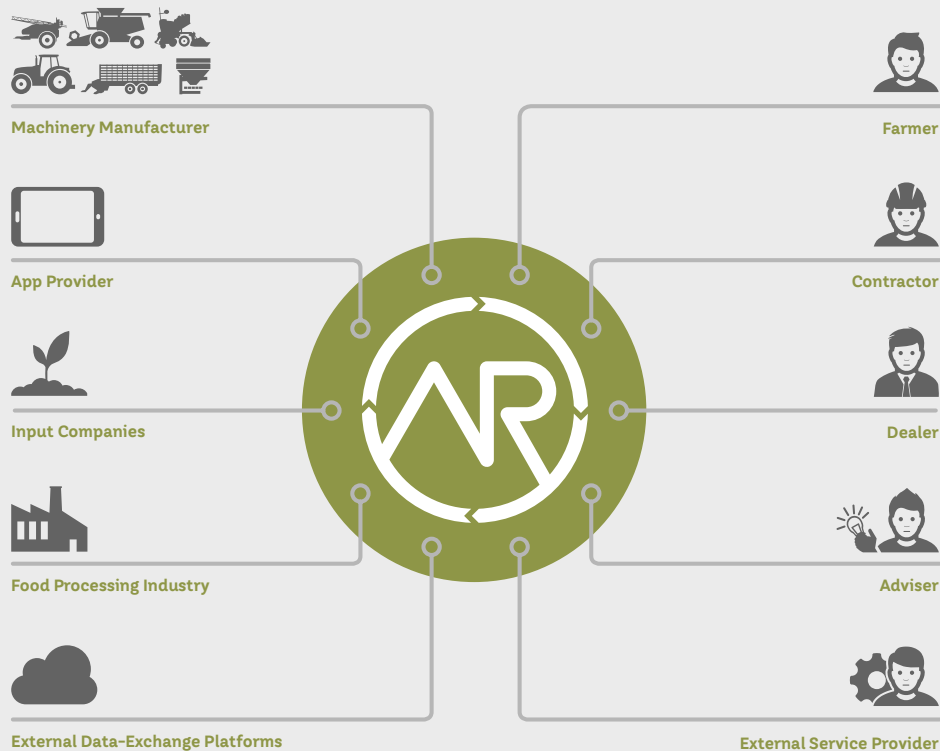

Thanks to the ISOBUS standard, machines from different manufacturers can easily communicate and exchange data with each other. In order to use this data once work has been completed, it makes sense to import it into a farm management system and evaluate it for documentation purposes. While data transfer between agricultural machines from different manufacturers is now straightforward, it has still been difficult to transfer data between machines and software products from different suppliers. This was due to a lack of standards - until now. That is why various agricultural equipment manufacturers, including PÖTTINGER, have joined forces to develop the agrirouter. The agrirouter enables manufacturer-independent, wireless data exchange between machines and agricultural software whilst reducing the number of communication interfaces to a minimum.

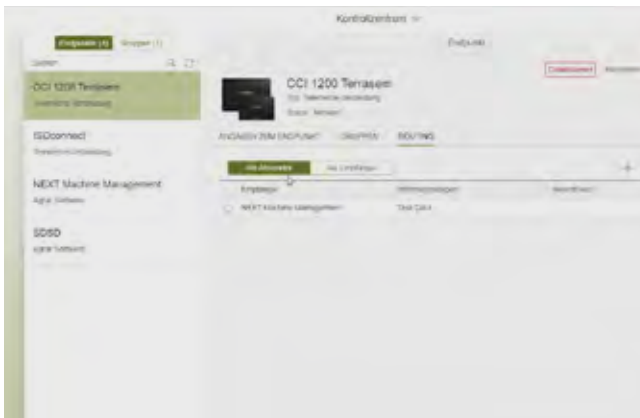

agrirouter - the "data forwarding service"

The agrirouter is a web-based data exchange platform. A free account can be used to send data such as jobs from your field indexing software directly to the CCI 1200 terminal in the tractor. This can also be carried out in the reverse direction by sending machine-related data directly to your farm PC.

Transparency

You define the routes on which the agrirouter transports your data.

Data security

agrirouter does not store any data - you retain full control.

We are ready for agrirouter

You can use the agrirouter for sowing technology on our VITASEM and AEROSEM with electric metering drives and TERRASEM seed drills. In the harvesting sector, our ISOBUS-compatible loader wagon range FARO, EUROPROFI, TORRO and JUMBO can be connected to the agrirouter.

These machines are able to document and make available data that is meaningful in terms of the work carried out. This data can be sent wirelessly from the tractor to the office as a standardised ISO-XML file using the CCI 1200 terminal. Likewise, you can send jobs wirelessly from your farm management system to the CCI 1200 terminal in the tractor. You no longer need a USB drive for data transfer. Even a machine fleet from a variety of manufacturers poses no problem for data transfer via agrirouter, provided the respective manufacturer is a member of the agrirouter consortium.

More information can be found at www.my-agrirouter.com

Accessories



	Intelligent front panel	AUTOCUT knife sharpening system	TWIN BLADE	Additional pick-up tracking roller	Folding pick-up jockey wheels
JUMBO 7380 DB	<input type="checkbox"/>	<input type="checkbox"/>	<input type="checkbox"/>	<input type="checkbox"/>	<input type="checkbox"/>
JUMBO 7400	<input type="checkbox"/>	<input type="checkbox"/>	<input type="checkbox"/>	<input type="checkbox"/>	<input type="checkbox"/>
JUMBO 7450 DB	<input type="checkbox"/>	<input type="checkbox"/>	<input type="checkbox"/>	<input type="checkbox"/>	<input type="checkbox"/>
JUMBO 7470	<input type="checkbox"/>	<input type="checkbox"/>	<input type="checkbox"/>	<input type="checkbox"/>	<input type="checkbox"/>
JUMBO 7520 DB	<input type="checkbox"/>	<input type="checkbox"/>	<input type="checkbox"/>	<input type="checkbox"/>	<input type="checkbox"/>
JUMBO 7540	<input type="checkbox"/>	<input type="checkbox"/>	<input type="checkbox"/>	<input type="checkbox"/>	<input type="checkbox"/>

More equipment options

- TWIN BLADE reversible knives
- Level sensor
- Duct cover
- Tyres:
 - 800/45R26.5"
 - 710/50R30.5"
 - 800/45R30.5"
- Hydraulic steered axles
- Electronic steered axles
- Intelligent trailed axles
- Lift axle for tridem with auto lowering function
- Terminals: POWER CONTROL, EXPERT 75 / CCI 1200
- LED work lights package 2 and 3
- Weighing system

- Flashing beacon
- EBS braking system
- Video systems
- Warning signs

Often ordered together



Pick-up handling trolley for models with rigid jockey wheels

Loading chamber raised for 26.5" tyres

Load containment system

Tridem chassis

30.5" tyres

3rd beater rotor

<input type="checkbox"/>	<input type="checkbox"/>	<input type="checkbox"/>	-	<input type="checkbox"/>	<input type="checkbox"/>
<input type="checkbox"/>	<input type="checkbox"/>	<input type="checkbox"/>	-	<input type="checkbox"/>	-
<input type="checkbox"/>	<input type="checkbox"/>	<input type="checkbox"/>	<input type="checkbox"/>	<input type="checkbox"/>	<input type="checkbox"/>
<input type="checkbox"/>	<input type="checkbox"/>	<input type="checkbox"/>	<input type="checkbox"/>	<input type="checkbox"/>	-
<input type="checkbox"/>	<input type="checkbox"/>	<input type="checkbox"/>	<input checked="" type="checkbox"/>	<input type="checkbox"/>	<input type="checkbox"/>
<input type="checkbox"/>	<input type="checkbox"/>	<input type="checkbox"/>	<input checked="" type="checkbox"/>	<input type="checkbox"/>	-

Configure your own machine.

■ = Standard, □ = Optional

Technical data

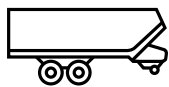

JUMBO	DIN volume with raised loading chamber for 26.5" tyres	Pick-up width	Number of knives	Knife spacing
JUMBO 7400	40 m ³ 42 m ³	2.3 m	48 piece	34 mm
JUMBO 7470	47 m ³ 49.3 m ³	2.3 m	48 piece	34 mm
JUMBO 7540	54 m ³ 56.6 m ³	2.3 m	48 piece	34 mm



JUMBO DB

JUMBO 7380 DB	38 m ³ 40 m ³	2.3 m	48 piece	34 mm
JUMBO 7450 DB	45 m ³ 47.3 m ³	2.3 m	48 piece	34 mm
JUMBO 7520 DB	52 m ³ 54.6 m ³	2.3 m	48 piece	34 mm

Overall length Overall width	Overall height 26.5" 30.5" tyres	Standard unladen weight	Permissible total weight	Maximum total weight
9.35 2.99 m	3.89 3.99 m	11,100 kg	22 t	24 t
10.66 2.99 m	3.89 3.99 m	12,000 kg	24 t	31 t
11.98 2.99 m	3.89 3.99 m	14,200 kg	34 t	34 t

9.35 2.99 m	3.89 3.99 m	11,450 kg	22 t	24 t
10.66 2.99 m	3.89 3.99 m	12,350 kg	24 t	31 t
11.98 2.99 m	3.89 3.99 m	14,550 kg	34 t	34 t



MyPÖTTINGER – it's easy. Anytime. Anywhere.

NEW STARTING 17/11/2021

Benefit from numerous advantages

MyPÖTTINGER is our customer portal that provides you with key information about your PÖTTINGER machines.

Get specific information and useful tips on your PÖTTINGER machines in "My machines". And find out more about the PÖTTINGER product range.

My machines

Add your PÖTTINGER machinery to "My machines" and assign a name. You will receive valuable information such as: useful tips on your machine, operating instructions, spare parts lists, maintenance information, as well as all the technical details and documentation.

Info on the product range

MyPÖTTINGER provides you with machine-specific information for all machines built starting 1997.

Scan the QR code on the machine's data plate with a smartphone or tablet or go to www.mypoettinger.com and enter the machine number from the comfort of your own home. You will immediately receive all the information on your machine, such as: instruction manuals, equipment options information, brochures, photos and videos.

ORIGINAL PARTS



CLASSIC

DURASTAR

DURASTAR PLUS

Rely on the original

PÖTTINGER Original Parts meet the highest demands in terms of functionality, reliability and performance. These are characteristics that PÖTTINGER is committed to delivering.

That is why we manufacture PÖTTINGER Original Parts from the highest quality materials. We ideally match each individual spare part and wear part to your machinery's overall system. This is because different soil and operating conditions often need to be taken into consideration.

We have been listening to our customers and now offer three different lines - CLASSIC, DURASTAR and DURASTAR PLUS - to make sure you have the right part to meet every requirement. Original parts are worth every cent, because know-how cannot be copied.

Your advantages

- Immediate and long-term availability.
- Maximum durability thanks to innovative production processes and the use of the highest quality materials.
- Avoidance of malfunctions due to a perfect fit.
- The best working results thanks to optimum match to the overall system of the machine.
- Save time and costs thanks to longer replacement intervals on wear parts.
- Comprehensive quality testing.
- Ongoing advancement through research and development.
- Worldwide spare parts supply.
- Attractive, competitive prices for all spare parts.

Wear parts

The CLASSIC line is for standard duty applications. With these ORIGINAL INSIDE parts we have defined the benchmark for quality, best price/performance ratio and reliability.

DURASTAR is the innovation on the wear components market - durable, high quality, productive and reliable.

Are you used to putting your machines to work in the most extreme conditions? Then the DURASTAR PLUS line is the right choice for you.



More Success with PÖTTINGER

- A family-owned company since 1871
Your reliable partner
- Specialist for arable and grassland
- Future-safe innovation for outstanding working results
- Roots in Austria - at home throughout the world

Two steps ahead

- No-compromise, high performance loader wagon
- Efficient and powerful with the highest capacity and a high mass flow rate
- The best forage quality and outstanding reliability
- Maximum cost effectiveness, convenient to operate and maintain

Ask for more information:

PÖTTINGER Landtechnik GmbH

Industriegelände 1
4710 Grieskirchen
Austria
Phone +43 7248 600-0
info@poettinger.at
www.poettinger.at

Alois PÖTTINGER UK Ltd.

15 St Marks Road, Corby
Northamptonshire,
NN18 8AN
United Kingdom
Phone + 44 1536 272 220
info@pottinger.uk
www.pottinger.uk

POETTINGER Canada Inc.

460 Rue Robinson Sud
Granby, QC, J2G 7N6
Canada
Phone +1 450 372 5595
Fax +1 866 417 1683
info@poettinger.ca
www.poettinger.ca

POETTINGER US, Inc.

393 Pilot Drive
Valparaiso, IN 46383
USA
Phone +1 219 510 5534
Fax + 1 219 707 5412
info@poettinger.us
www.poettinger.us

PÖTTINGER Australia PTY LTD

11 Efficient Drive
Truganina VIC 3029
Australia
Phone +61 3 8353 2770
info@poettinger.com.au
www.poettinger.com.au

POETTINGER Ireland Ltd.

Glenaleamy, Powerstown Road,
Clonmel, Co. Tipperary
Ireland
Phone +353 52 6125766
info@poettinger.ie
www.poettinger.ie

Importer for New Zealand:

Origin Agroup
PO Box 673, 57 Hautapu Road
Cambridge
New Zealand
Phone +64 7 823 7582
info@originagroup.co.nz
www.originagroup.co.nz

Importer for South Africa:

VALTRAC
Cnr. Water & Buiten Street
9585 Parys
South Africa
Phone +27 56 817 7338 7308
wynn@valtrac.co.za
www.valtrac.co.za